

Technical Information

Turbimax CUE21 / CUE22

Turbidimeter for on-line measurement



Application

On-line continuous monitoring of clean water:

- Drinking water
- Treated process water

Your benefits

- Versions with white light source and infrared light source available
- Fast and easy calibration
 - Complete primary calibration in less than 5 minutes
 - Verification in seconds
- Reduced calibration costs and quick response times thanks to low volume sample chamber
- Automatic continuous ultrasonic cleaning (Autoclean) increases cleaning intervals dramatically
- Simple modular design
- Easy to use and service
- Affordable thanks to modular microprocessor based technology
- Digital high-speed connections through RS-485 with Modbus

Optional Features:

- Flow chamber for bubble suppression
- Reusable calibration kit

Function and system design

Measuring principle

Turbidity measurement

For turbidity measurement a light beam is sent through the medium and is diverted from its original direction by optically denser particles, e.g. solid matter particles.

Measuring methods

90° WL scattered light method

The measurement uses the standardised 90° scattered light method acc. to U.S. EPA 180.1.

The turbidity of the medium is determined by the amount of scattered light. The transmitted white light beam is scattered by the solid matter particles in the medium. The scattered beams are detected by scattered light receivers which are arranged at an angle of 90° to the white light source.

90° NIR scattered light method

The measurement uses the standardized 90° scattered light method acc. to ISO 7027 / EN 27027.

The turbidity of the medium is determined by the amount of scattered light. The transmitted light beam with a wavelength in the near-infrared range is scattered by the solid matter particles in the medium. The scattered beams are detected by scattered light receivers which are arranged at an angle of 90° to the infrared light source.

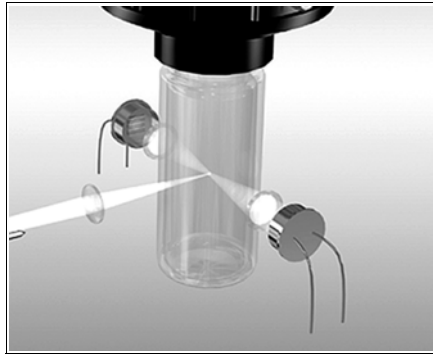

90° scattered light method

Functions

IR or white light measurement

The Turbimax is available as infrared version, CUE21, to meet the design criteria specified in ISO 7027 and DIN 27027. The white light version, CUE22, meets the design criteria on turbidity measurement specified by the US EPA 180.1. Both versions have long life lamps.

Backlit LCD

The backlit LCD allows for easy readability in low light or no light conditions. The backlight is intended for continuous operation. The brightness can be adjusted in a menu in the CONFIG mode.

Vapor purge

The Turbimax is equipped with a continuous vapor purge system. A replaceable desiccant pouch in the lower portion of the instrument dries the air. System heat is used to warm the air. A fan inside the instrument continuously circulates heated dry air around the optical well and the flow through cuvette. This eliminates the need for a dry purge line.

Alarms

The Turbimax provides two relays that are designed to operate as two independent, programmable alarms. The alarms can be configured to activate when the measured turbidity level is higher or lower than the programmed alarm level for a given period of time. The alarm function also allows to set delay times.

Ultrasonic cleaning

This option is used to continuously clean the flow through cuvette. It is not intended to clean already dirty cuvettes or to replace manual cleaning entirely. The system will increase the time between cleanings dramatically. Please note that the system requires the use of a special cuvette.

RS-485 outputs

Turbimax has the capability to operate in two different RS-485 modes, a simple communication mode and Modbus protocol communication.

- The simple communication mode provides communication over programs such as the HyperTerminal that is included with most Microsoft Windows packages. You can also use Visual Basic or other programs. The default communication parameters are 8 bits, no parity and 1 stop bit.
- Modbus protocol communication is available for all models. The Modbus information is covered in a separate manual.

Flow controller

The flow controller limits the flow, in high-pressure systems, to safe flow limits of less than 1 liter/minute.

Measuring system

The Turbimax CUE21 / CUE22 measuring system comprises:

- Turbimax turbidimeter with installed cuvette and desiccant pouch
- Connecting tubing with
 - fittings for flow through assembly
 - shutoff clamp
 - backpressure valve
 - drain vent screw (in pressurized systems)
- Sensor interconnect cable

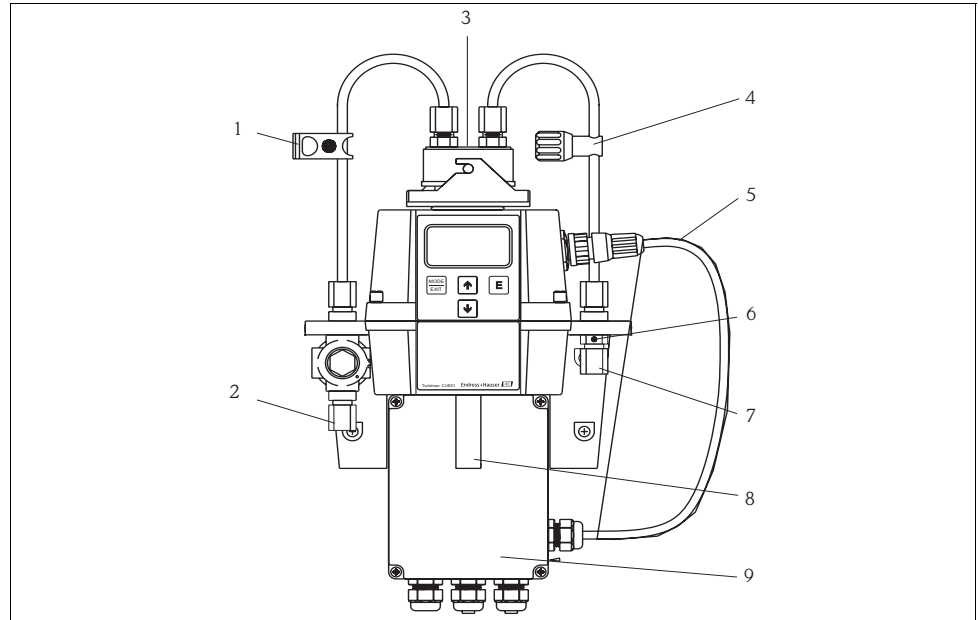

Turbimax CUE21 system (example)

- | | | | |
|---|---|---|--|
| 1 | Shutoff clamp | 6 | Drain vent |
| 2 | Intake tubing connection (for OD 8 mm (0.31"), ID 4.75 mm (0.19") tubing) | 7 | Drain tubing connection (for OD 8 mm (0.31"), ID 4.75 mm (0.19") tubing) |
| 3 | Flowhead | 8 | Emergency drain |
| 4 | Backpressure valve | 9 | Field terminal box |
| 5 | Sensor interconnect cable | | |

Input

Measured variables

Turbidity

Measuring range

CUE21: 0 to 1000 NTU /FNU
CUE22: 0 to 100 NTU /FNU

Output

Output signal	4 to 20 mA, galvanically isolated	
Signal on alarm	2 mA in case of an error	
Load	max. 600 Ω	
Communications port	Bi-directional RS-485, Modbus optional	
Relays	Switching voltage: Switching current:	max. 240 VAC max. 2 A
Limit value and alarm functions	Setpoint adjustment: CUE21: CUE22: Alarm delay:	 0 to 1000 NTU 0 to 100 NTU 0 to 30 s

Power supply

Electrical connection

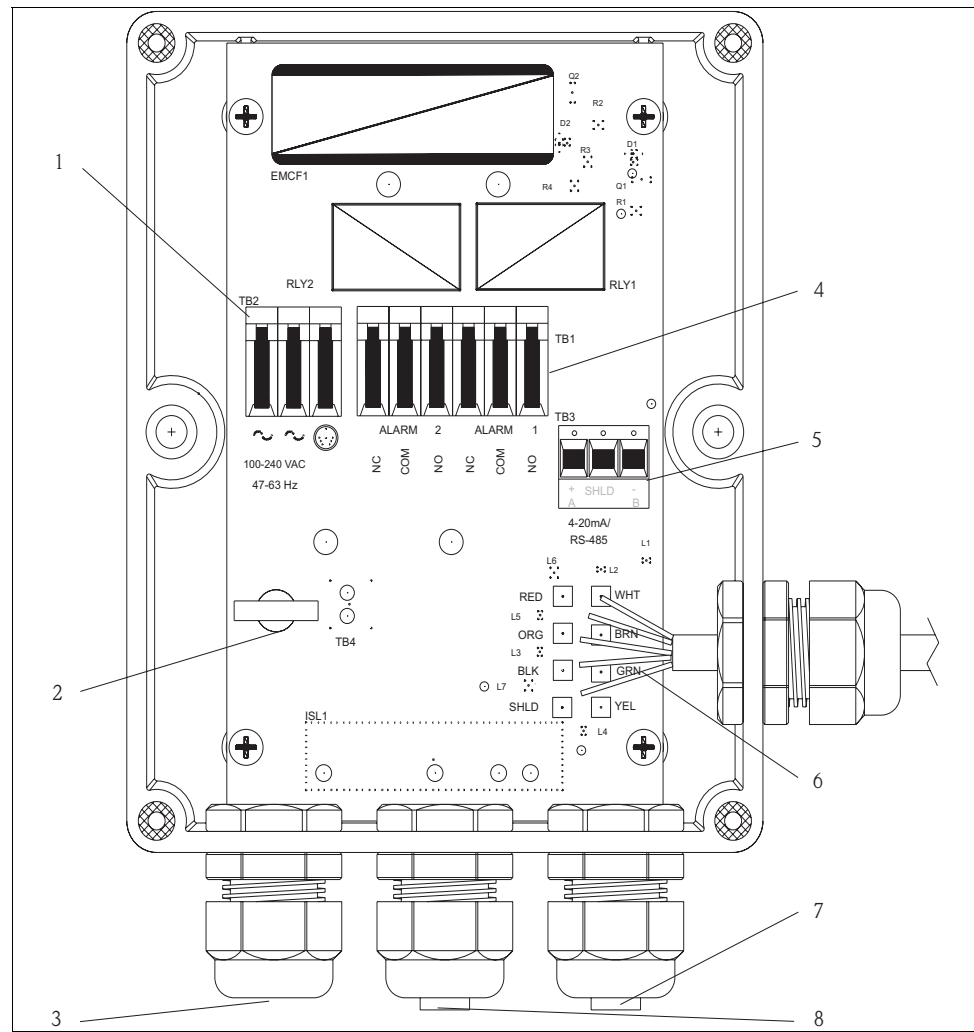

Field terminal box

1	Power supply terminal block	5	4 to 20 mA / RS485 terminal block
2	Power cable strain relief	6	Sensor wiring
3	Power cable gland	7	4 to 20 mA / RS485 cable gland
4	Alarms terminal block, 240 VA, 2A	8	Alarm cable gland

Power supply

100 to 240 VAC, 47 to 63 Hz, 80 VA switching power supply

Performance characteristic

Response time

adjustable 1 to 100 % (approx. 5 to 500 seconds)
CUE21: 0 to 1000 NTU
CUE22: 0 to 100 NTU

Reference temperature

25°C (77°F)

Resolution

0.0001 NTU (below 10 NTU)

Maximum measured error

below 40 NTU: $\pm 2\%$ of reading or ± 0.02 NTU whichever is greater
above 40 NTU: $\pm 5\%$ of reading

Repeatability

$\pm 1\%$ of reading

Installation

Wall mounting

Turbimax CUE21 / CUE22 is recommended for indoor use.

When mounting the instrument note the following:

- Check that the temperature does not exceed the maximum permitted operating temperature range (0 to 50 °C (32 to 122 °F)).
- Leave a free area of approx. 0.20 m (8.00") above the instrument. This will ensure enough room for calibration and cuvette maintenance.
- Mount the instrument as close as possible to the sampling point to ensure a quick response time, within 2 to 3 m (6 to 10 ft).

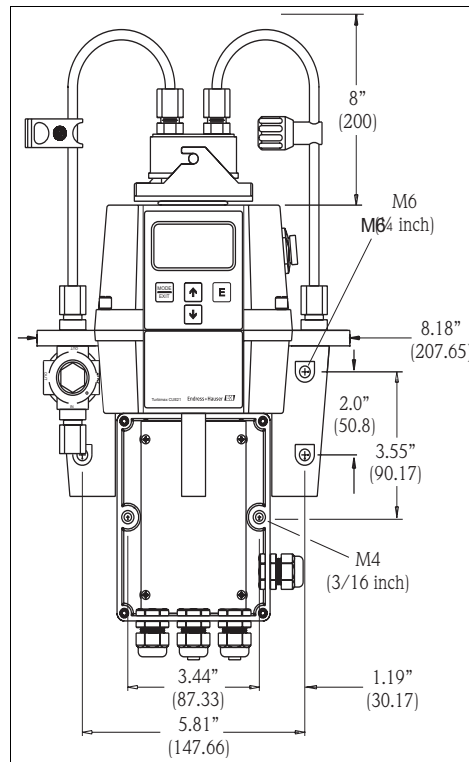

Mounting dimensions front view

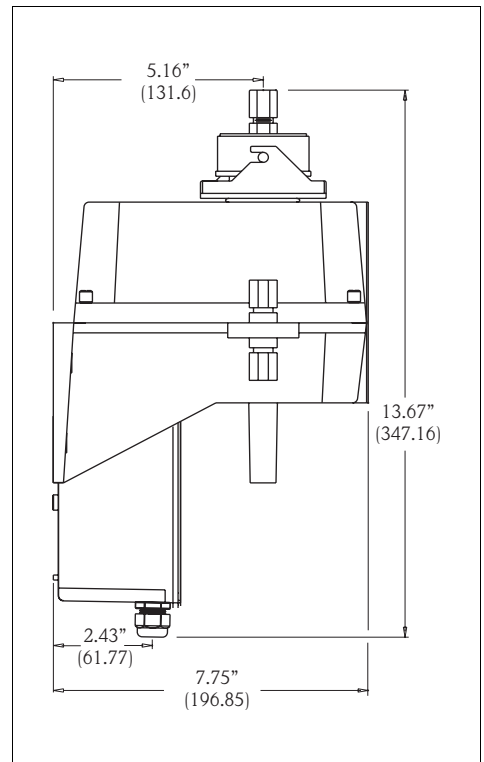

Mounting dimensions lateral view

Environment

Storage temperature -20 to +60°C (-4 to +140°F)

Ingress protection IP 66 / NEMA 4x

Insulation rating Double insulated, pollution degree 2

Overvoltage protection Category II

Relative humidity max. 95%, non-condensing

Altitude up to 2000 m

Process

Process temperature 1 to 50°C (34 to 122°F)

Medium temperature range 1 to 50°C (34 to 122°F)

Process pressure max. 13.78 bar (200 psi)
controlled by integral pressure regulator

Flow rate 0.1 to 1 liter/min. (0.026 to 0.26 US.gal/min.)

Mechanical construction

Dimensions H x W x D: 347.16 x 207.65 x 196.85 mm (13.7" x 8.2" x 7.8")

Weight 2 kg (4.4 lbs.)

Materials

Housing:	ABS
Flow-through head:	Nylon
Sample cuvette:	Borosilicate glass
Sample cuvette seal:	Silicon
Flow-through fittings:	Polypropylene
Flow-through lock down pins:	Stainless steel (AISI 304 or AISI 303)
Inlet tube:	Stainless steel (AISI 316)

Light source

Turbimax CUE21:	Infrared LED, 860 nm
Turbimax CUE22:	White light Tungsten lamp, ~600 nm, 2250 °K

Human interface

Display and operating elements

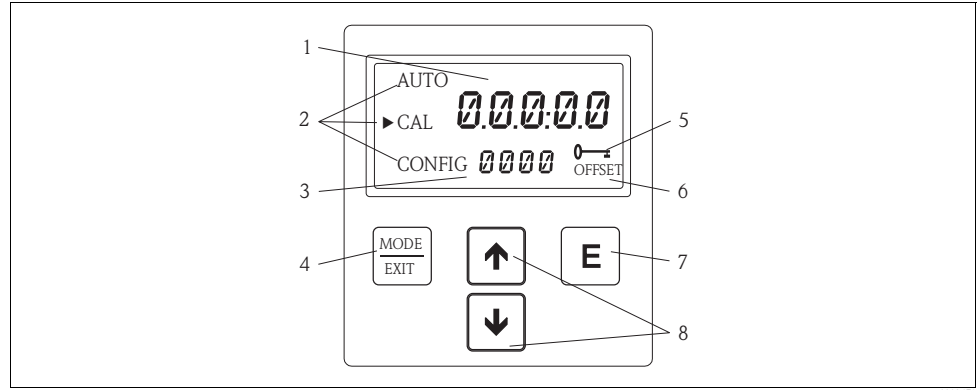

Display and operating elements

- 1 Display of turbidity levels and user guidance in configuration
- 2 Mode arrow to indicate instrument operating mode; AUTO (measurement), CAL (calibration), CONFIG (configuration)
- 3 Display of error messages and user guidance
- 4 MODE/EXIT key used to cycle between the three instrument operating modes
- 5 Icon indicating the use of access code
- 6 Icon indicating OFFSET mode
- 7 key to confirm an option or mode that is highlighted or chosen
- 8 keys used to change settings

Certificates and approvals

CE symbol

Declaration of conformity

The product meets the legal requirements of the harmonized European standards.
The manufacturer confirms compliance with the standards by affixing the **CE** symbol.

ETL approval

- Tested and passed ETL (tested to UL3111-1), 1st Edition 1994, w/Bulletin June 5, 1996
- Tested and passed ETLc (tested to CSA C22.2#1010.1-92)

EMC compatibility

Interference emission and interference immunity complies with EN 61326: 1997 / A1: 1998

Ordering information

Turbimax CUE21 compact device, infrared

Power supply	
A	100 to 240 VAC
Output	
1	4 to 20 mA or RS-485
Version	
A	Standard
CUE21-	complete order code

Turbimax CUE22 compact device, white light

Power supply	
A	100 to 240 VAC
Output	
1	4 to 20 mA or RS-485
Version	
A	Standard
CUE22-	complete order code

Scope of delivery

The scope of delivery comprises:

- 1 Turbimax CUE21 / CUE22 turbidimeter
- 1 Field terminal box
- 1 Flow through assembly
- 1 Desiccant pack
- 1 Cuvette (single pack)
- 1 Tubing kit including
 - 1 shutoff clamp
 - 1 backpressure valve
 - 2 connecting tubes with fittings for flow through assembly
 - 1 drain vent screw (used in pressurized systems)
- 1 Operating Instructions BA395C/07/en

Accessories

Calibration solutions

Calibration kit CUE21 / CUE23 / CUE24, full range

- 0.02 NTU
- 10.0 NTU
- 1000 NTU

Order no.: 51518580

Calibration kit CUE22, full range

- 0.02 NTU
- 10.0 NTU
- 100 NTU

Order no.: 71030102

Ultrasonic cuvette

- Replacement cuvette with ultrasonic transducer allowing to use the ultrasonic cleaning feature
- Order no.: 51518576
-

Flow chamber

- Flow chamber CUE21 / CUE22 for air bubble suppression
- Order no.: 51518575
-

United States

Endress+Hauser, Inc.
2350 Endress Place
Greenwood, IN 46143
Tel. 317-535-7138
Sales 888-ENDRESS
Service 800-642-8737
fax 317-535-8498
inquiry@us.endress.com
www.us.endress.com

Canada

Endress+Hauser Canada
1075 Sutton Drive
Burlington, ON L7L 5Z8
Tel. 905-681-9292
800-668-3199
Fax 905-681-9444
info@ca.endress.com
www.ca.endress.com

Mexico

Endress+Hauser, México, S.A. de C.V.
Fernando Montes de Oca 21 Edificio A Piso 3
Fracc. Industrial San Nicolás
54030. Tlalnepantla de Baz
Estado de México
México
Tel: +52 55 5321 2080
Fax +52 55 5321 2099
eh.mexico@mx.endress.com
www.mx.endress.com

TI395C/24/ae/10.07
© 2007 Endress+Hauser, Inc.